

HGX7/1620-4 S

Engine: 380-420V Y/YY -3- 50Hz PW

Refrigerant: R404A, R507

Subject:

Performance data

Application: Refrigeration & AC

Refrigerant	R404A, R507	Compressor refrigeration capacity	107.00 kW
Reference temperature	Dew point	Evaporator refrigeration capacity	107.00 kW
Power supply	50 Hz, 400 V	Power consumption	42.20 kW
Supply frequency	50 Hz	Current draw (400 V)	73.10 A
Evaporating temperature	5.0 °C	Coefficient of performance (COP/EER)	2.52
<i>Evaporating pressure (abs.)</i>	<i>7.06 bar</i>	Condensing capacity	149.00 kW
Condensing temperature	50.0 °C	Mass flow	1.002 kg/s
<i>Condensing pressure (abs.)</i>	<i>22.98 bar</i>	Discharge end temperature	81.1 °C ¹⁾
Suction gas temperature	20 °C		
Subcooling (outside cond.)	0 K		
Usable superheat	100%		

Certifications



ASERCOM certified performance data

The performance data of compressors bearing this label has been certified to the strict requirements of ASERCOM.

ASERCOM is the Association of European Refrigeration Compressors and Controls Manufacturers. Information about the Association and the constantly updated overview of certified Bock compressors can be found at www.asercom.org.

This certification is based on EN 12900. This signifies: 20 °C suction gas temperature without liquid subcooling at 50 Hz power supply frequency.

¹⁾ The stated value of the discharge end temperature is a mere calculated value. Additional cooling and heat dissipation are not considered. Deviations (particularly in deep freezing applications) from the real measured discharge temperature during operation are possible.

Subject to change without notice

To:

From:

22.04.2022
Page 1 of 9

VAP 11.10.0

HGX7/1620-4 S



Engine: 380-420V Y/YY -3- 50Hz PW

Refrigerant: R404A, R507

Subject:

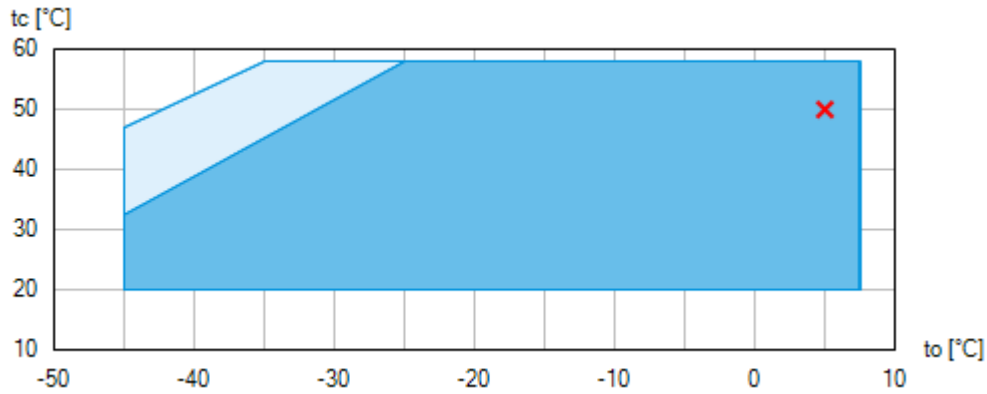
Operating limits



-  Unlimited application range
-  Supplementary cooling or reduced suction gas temperature ($\Delta t_{oh} < 20K$)
-  Supplementary cooling and reduced suction gas temperature ($\Delta t_{oh} < 20K$)

Compressor operation is possible within the limits shown on the diagrams of application. Please note the coloured areas. Compressor application limits should not be chosen for design purposes or continuous operation. Axis values refer to dew point (saturated vapour line).

Subject to change without notice

To:

From:

22.04.2022
Page 2 of 9

VAP 11.10.0

HGX7/1620-4 S

Engine: 380-420V Y/YY -3- 50Hz PW

Refrigerant: R404A, R507

Subject:

Technical data

Number of cylinders / Bore / Stroke	6 / 70 mm / 70 mm
Displacement 50/60 Hz (1450/1740 ¹ /min)	140,60 / 168,70 m ³ /h
Voltage ¹⁾	380-420V Y/YY -3- 50Hz PW
	440-480V Y/YY -3- 60Hz PW
Winding divided into	50% / 50%
Max. working current ²⁾	83.0 A
Max. power consumption ²⁾	47.4 kW
Starting current (rotor blocked) ²⁾	268.0 / 373.0 A
Motor protection	MP10
Protection terminal box	IP 65
Weight	299 kg
Max. permissible overpressure (g) (LP/HP) ³⁾	19 / 28 bar
Connection suction line SV	54 mm - 2 1/8 "
Connection discharge line DV	42 mm - 1 5/8 "
Lubrication	Oil pump
Oil type R134a, R404A, R407A/C/F, R448A, R449A, R450A, R513A	BOCKlub E55
Oil type R22	BOCKlub A46
Oil charge	4,5 Ltr.
Oil sump heater	230 V - 1 - 50/60 Hz, 140 W
Dimensions Length / Width / Height	830 / 510 / 500 mm

1) Tolerance ($\pm 10\%$) relates to the mean value of the voltage range. Other voltages and current types on request

All data are based on voltage rms values

PW = part winding, motors for part winding starting
(no start unloaders required)
Designs for Y/D on request

2) - The stated value for the max. power consumption is valid for the adjusted power supply.

- Starting current (rotor blocked):

- Part winding (PW) motors: Winding 1 / Winding 1+2
- Delta/Star (Δ/Y) motors: Δ / Y

- Take account of the max. operating current / max. power consumption for designing motor contractors, feed lines, fuses and motor protection switches. Motor contractors: Consumption category AC3.

3) LP = Low pressure
HP = High pressure

Subject to change without notice

To:

From:

22.04.2022
Page 3 of 9

VAP 11.10.0

HGX7/1620-4 S

Engine: 380-420V Y/YY -3- 50Hz PW

Refrigerant: R404A, R507

Subject:

Performance data table

Application: Refrigeration & AC
Reference temperature: Dew point
Supply frequency: 50 Hz
Voltage: 400 V
Suction gas temperature: 20 °C
Subcooling (outside cond.): 0 K

tc [°C]		to [°C]									
		0.0	-5.0	-10.0	-15.0	-20.0	-25.0	-30.0	-35.0	-40.0	-45.0
30.0	Q [W]	127000	106000	86900	70500	56300	44000	33600	25000	17900	12400
	P [kW]	30.90	29.40	27.60	25.40	23.10	20.50	17.90	15.20	12.60	10.10
	I [A]	56.50	54.50	52.20	49.70	47.00	44.30	41.80	39.40	37.20	35.20
35.0	Q [W]	118000	97700	80300	65000	51700	40300	30600	22600	16000	10700
	P [kW]	33.20	31.40	29.10	26.70	24.00	21.10	18.20	15.40	12.50	9.89
	I [A]	59.60	57.00	54.10	51.10	48.00	45.00	42.10	39.50	37.10	35.10
40.0	Q [W]	108000	89700	73500	59400	47100	36600	27600	20200	14000	8970
	P [kW]	35.40	33.10	30.60	27.70	24.70	21.60	18.40	15.30	12.30	9.44
	I [A]	62.70	59.40	56.00	52.40	48.90	45.50	42.30	39.40	36.90	34.70
45.0	Q [W]	98500	81600	66800	53800	42500	32800	24600	17800	12100	7360
	P [kW]	37.50	34.80	31.80	28.60	25.30	21.90	18.50	15.10	11.80	8.80
	I [A]	65.70	61.80	57.60	53.50	49.50	45.80	42.30	39.20	36.50	34.30
50.0	Q [W]	88900	73400	59900	48100	37800	29100	21600	15400	10100	
	P [kW]	39.40	36.30	33.00	29.40	25.70	22.00	18.30	14.70	11.20	
	I [A]	68.70	64.00	59.20	54.50	50.00	45.90	42.20	38.90	36.00	



Supplementary cooling or reduced suction gas temperature ($\Delta t_{oh} < 20K$)



Supplementary cooling and reduced suction gas temperature ($\Delta t_{oh} < 20K$)

to Evaporating temperature
tc Condensing temperature
Q Compressor refrigeration capacity
P Power consumption
I Current draw

Subject to change without notice

To:

From:

22.04.2022
Page 4 of 9

VAP 11.10.0

HGX7/1620-4 S

Engine: 380-420V Y/YY -3- 50Hz PW

Refrigerant: R404A, R507

Subject:

Scope of supply

Semi-hermetic six-cylinder reciprocating compressor with drive motor
Single-section compressor housing with hermetically integrated electric motor

Oil pump

Possibility of connection of oil level controllers ESK, AC+R or CARLY

Winding protection with PTC resistor sensors and electronic trigger unit MP 10

Oil pump cover with screw-in option for oil differential pressure sensor DELTA-P II

Possibility of connection of oil level controllers Traxoil ¹⁾

Possibility for connection of oil pressure safety switch MP54

Oil charge:

HG: **BOCK**lub A46

HGX: **BOCK**lub E55

Two sight glasses

Prepared for capacity regulator (2 cylinder covers)

Pressure relief valve

Suction and discharge line valve

Inert gas charge

4 anti-vibration pads enclosed

Accessories

Start unloader 230 V - 1 - 50/60 Hz, IP65, less check valve,
including thermal protection thermostat (posistor tracer)

Start unloader by means of a ESS (Electronic Soft Start), 400 V - 3 - 50/60 Hz, IP20 (Connection clamps IP00) for
installation in switch cabinet ²⁾

Capacity regulator 230 V - 1 - 50/60 Hz, IP65
1-2 capacity regulator = 66/33% residual capacity

Oil sump heater 230 V - 1 - 50/60 Hz, 140 W

Thermal protection thermostat per cylinder cover ³⁾

Oil differential pressure sensor DELTA-P II 220-240 V - 1 - 50/60 Hz ²⁾

Oil service valve

Connection piece suction and discharge valve in welding design

Oil pressure safety switch MP54 230 V - 1 - 50/60 Hz, IP20 ²⁾

Subject to change without notice

To:

From:

22.04.2022
Page 5 of 9

VAP 11.10.0

HGX7/1620-4 S

Engine: 380-420V Y/YY -3- 50Hz PW

Refrigerant: R404A, R507

Subject:

Water-cooled cylinder covers

Additional fan

230 V AC - 1 - 50 Hz, 97 W, IP44

230 V AC - 1 - 60 Hz, 128 W ²⁾

Intermediate adapter for discharge line valve ²⁾

Special voltage and/or frequency (on request)

- 1) Only with additional adapter possible
- 2) Enclosure
- 3) Mounted

Subject to change without notice

To:

From:

22.04.2022
Page 6 of 9

VAP 11.10.0

HGX7/1620-4 S

Engine: 380-420V Y/YY -3- 50Hz PW

Refrigerant: R404A, R507

Subject:

Dimensions and connections

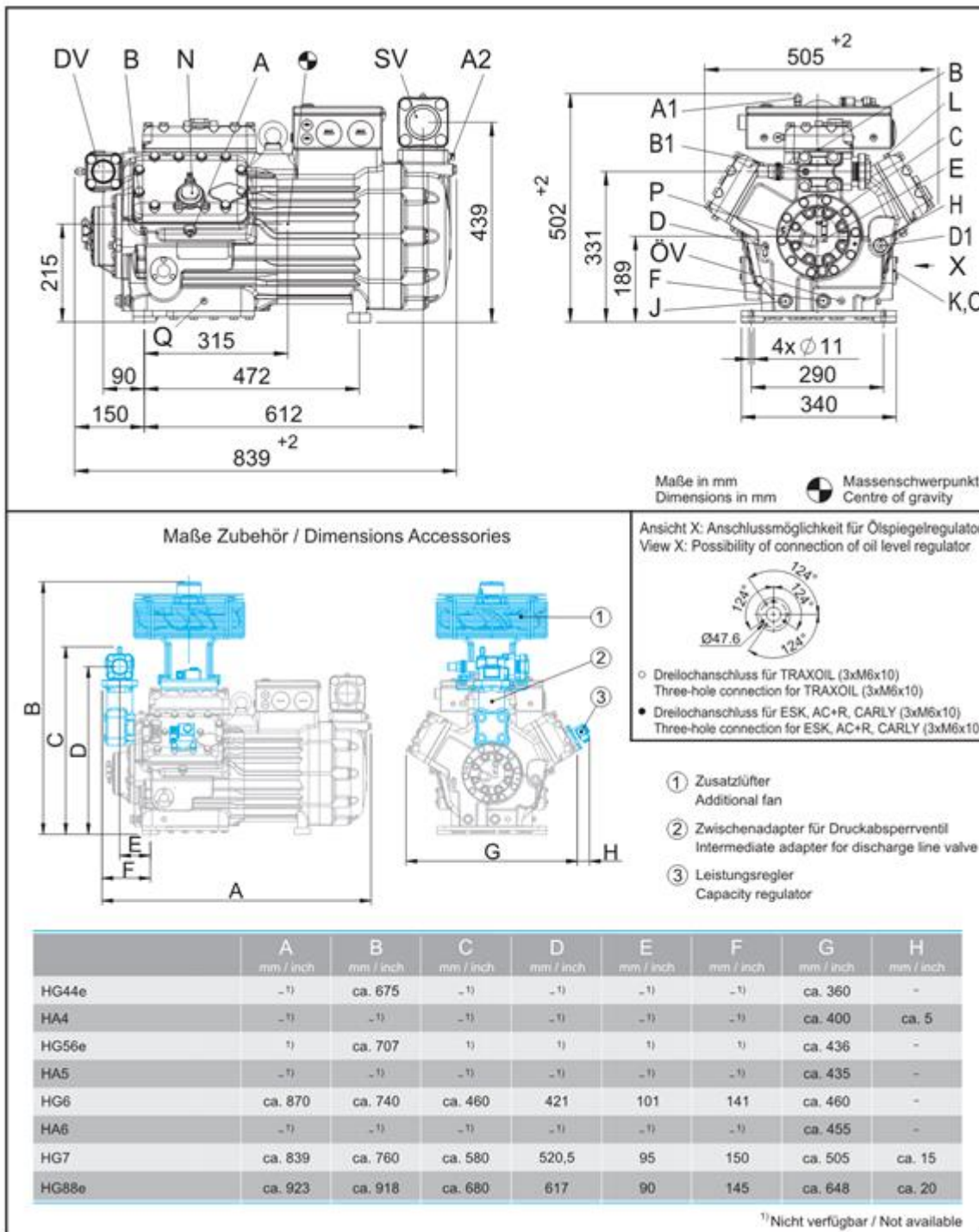

Subject to change without notice

To:

From:

22.04.2022
Page 7 of 9

VAP 11.10.0

HGX7/1620-4 S

Engine: 380-420V Y/YY -3- 50Hz PW

Refrigerant: R404A, R507

Subject:

SV	Suction line valve, tube \varnothing ¹⁾	54 mm - 2 1/8 "
DV	Discharge line valve, tube \varnothing ¹⁾	42 mm - 1 5/8 "
A	Connection suction side, not lockable	1/8 " NPTF
A1	Connection suction side, lockable	7/16 " UNF
A2	Connection suction side, not lockable	1/4 " NPTF
B	Connection discharge side, not lockable	1/8 " NPTF
B1	Connection discharge side, lockable	7/16 " UNF
C	Connection oil pressure safety switch OIL	7/16 " UNF
D	Connection oil pressure safety switch LP	7/16 " UNF
D1	Connection oil return from oil separator	1/4 " NPTF
E	Connection oil pressure gauge	7/16 " UNF
F	Oil drain	M 22 x 1.5
H	Oil charge plug	M 22 x 1.5
J1	Oil sump heater	M 22 x 1.5
K	Sight glass	-
L	Connection thermal protection thermostat	1/8 " NPTF
N	Connection capacity regulator	M 45 x 1.5
O	Connection oil level regulator	3 x M 6
ÖV	Connection oil service valve	1/4 " NPTF
P	Connection oil differential pressure sensor	M 20 x 1.5
Q	Connection oil temperature sensor	1/8 " NPTF

1) Brazing connection

Subject to change without notice

To:

From:

22.04.2022
Page 8 of 9

VAP 11.10.0

HGX7/1620-4 S

Engine: 380-420V Y/YY -3- 50Hz PW

Refrigerant: R404A, R507

Subject:

BOCK colour the world
of tomorrow

Product photo



Subject to change without notice

To:

From:

22.04.2022
Page 9 of 9

VAP 11.10.0